

# THERMOSTAT TM45A2/AMPM

VIEW FROM HIGHT

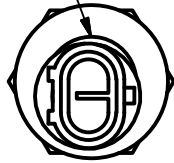

AMP SUPERSEAL 282104-1

## TECHNICAL FEATURES

BODY: IN BRASS  
 FIX SET SWITCHING: 50°C  
 MAX. WORKING PRESSURE: 200[BAR]  
 HYDRAULIC CONNECTION: 3/8"BSP-M  
 WORKING TEMPERATURE: FROM -20°C TO 120°C  
 SWITCHING ACCURACY: 3.5°C  
 FIXED HYSTERESIS VALUE: ~12° OF SETTED VALUE  
 WEIGHT: ~0.25[KG]

with 0,32m.  
of electric wire

## ELECTRIC FEATURES

ELECTRIC PROTECTION: DIN 40050 : IP 67  
 MAX. ELECTRIC LOAD ON CONTACTS: 220[V]AC - 10[A]  
 125[V]AC - 15[A]  
 24[V]DC - 8[A]  
 12[V]DC - 10[A]  
 CONTACTS TYPE: SIMPLE CONTACTS NO

Body stamping  
+Series Number

FOX CODE: **TM45A2/AMPM**

CUSTOMER CODE: **HHI02201**

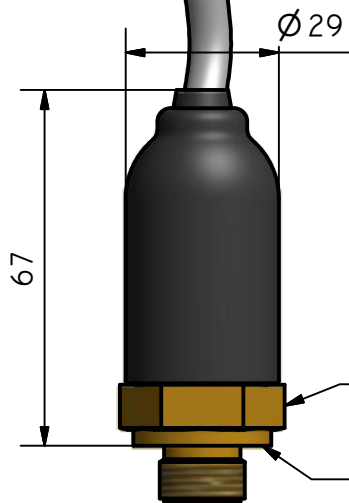

CH. 27

INCORPORATED SEAL

Drawn MORENO	Checked	Approved	Date	Date 14/11/2018	
 FOX S.R.L. VIA ROMAGNA, 6 OPERA - MI - ITALY			THERMOSTAT TM45A2/IP67AMPM		
			TM45A2-AMPM_IKRON-HHI02201	Edition	Sheet 1 / 1